

KEY DATA

- Design of the orifice plate integrated in the meter run according to ISO5167-1 & ISO5167-2 or ISO/TR 15377 or ASME MFC-3M or ASME MFC-14M standards
- Recommended for gas, liquid or steam
- Recommended internal pipe diameter from 15 mm to 300 mm (below, choose an integrated orifice according to ASME MFC-14M standard, beyond, choose an unassembled solution)
- Reynolds number from 80 to 10^8
- Possibility of integrating a nozzle in the meter run - design according to the ISO 5167-3 standard
- Accuracy : from 0,5% of the max flowrate
- Repeatability of measurement : 0,1%



BENEFITS

- ▶ Complete and flexible measuring element for easy on-site installation - delivered assembled ready to install
- ▶ Cost-effective measurement system : low installation cost and maintenance-free
 - ▶ Very long life-time product, no drift over time
- ▶ High measurement accuracy thanks to the adjustment of all components during manufacturing
 - ▶ No need of calibration



The meter run is a one-piece assembly consisting of an orifice plate (or nozzle) mounted between flanges, with tie rods, gaskets and lengths of upstream and downstream piping. The assembly is carried out in our workshops in compliance with standards (in particular with regard to the roughness of the upstream and downstream tubes, the centering of the primary element, the straight lengths, etc.) in order to achieve optimal precision measurement.

STANDARDS

- ISO 5167-1 & ISO 5167-2 for the orifice plate or ISO 5167-3 for the nozzle
- ISO/TR 15377
- ASME MFC-3M
- ASME MFC-14M
- AGA3 / API MPMS 14.3

TECHNICAL CHARACTERISTICS

- Fluid temperature ⁽¹⁾ : cryogenic to +800°C
- Fluid type : gas, steam, monophasic liquid
- Primary element materials ⁽²⁾ : carbon steel, stainless steel, monel, hastelloy, inconel, duplex, super duplex, titanium, tantalum, PVC, PTFE...
- Piping materials : carbon steel, stainless steel, monel, hastelloy, inconel, duplex, super duplex, titanium, tantalum, PVC, PTFE...
- Accuracy : from 0,5% of the max flowrate
- Maximum operating pressure : limited by the flange rating
- Connection of the meter run to the pipe : connection with flanges recommended. After welding the flanges on the meter run, honing of the upstream and downstream tubes is carried out to comply with the roughness and circularity criteria of the standard.

(1) No temperature restriction with remote-mounted transmitter, otherwise +125°C max

(2) For an aggressive fluid, applying a specific coating on the part in contact with the fluid can increase the product lifetime

The meter run is recommended for internal pipe diameters D from 15 mm to approximately 300 mm.

Beyond that, it is more difficult to carry and install this one-piece assembly (the lengths of the upstream and downstream pipes increase with this diameter D).



However, its manufacturing and assembly are still possible.

Below, choose an integrated orifice according to ASME MFC-14M⁽³⁾.

MOUNTING OF THE PRIMARY ELEMENT

- Mounting between flanges or inserted between 2 carrier rings with annular slots - monobloc version available as well (see page 4)
- Flange types : ISO PN 2,5 to PN 420, ASME 150# to 2500#, API flanges
- Connection between straight sections according to the standard:
Variable upstream and downstream straight lengths according to β ($\beta=d/D$) and according to the upstream fittings - see upstream straight lengths table on page 5
These lengths can be reduced with an additional uncertainty on the discharge coefficient of 0.5% - see page 5
- Gasket types : flat gasket (spiral wound, graphite, PTFE) or RTJ (soft iron, inox, monel...)

DRAWING

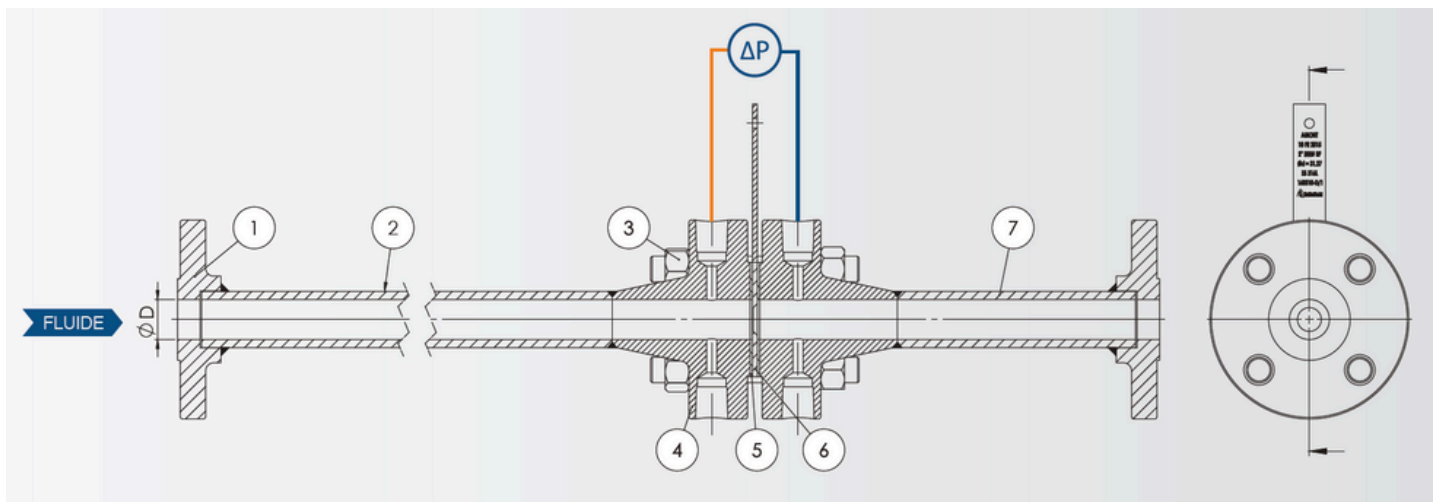

- ① Flange ② Upstream tube ③ Boltings ④ Orifice flange⁽⁴⁾ ⑤ Gasket
⑥ Orifice plate⁽⁵⁾ ⑦ Downstream tube

(3) An integrated orifice is a complete measuring element with orifice plate, gaskets, tie rods and special flanges (for direct mounting of the manifold and differential pressure transmitter) including upstream and downstream straight lengths. Suitable for internal pipe diameters ≤ 40 mm. Standard: ASME MFC-14M. Consult us

(4) Mounting also possible between 2 carrier rings with annular slots or in monobloc version - see page 4

(5) All types of orifice plates as well as nozzles can be mounted in a metre run

PRESSURE TAPS TYPES

- flange tap ⁽⁶⁾ (or 1"/1")
with orifice flanges
ASME standard only from 300#

➤ The measurement is executed at 25,4 mm (1 inch) from the upstream and downstream plate face

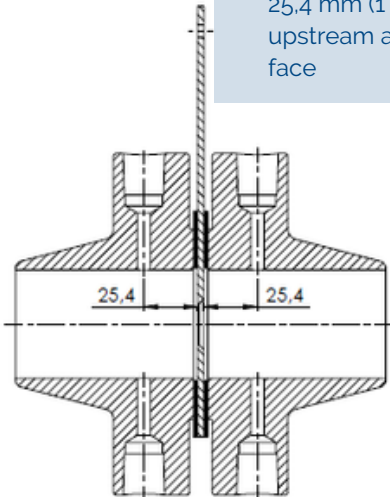

- Easily interchangeable measuring element
- Plate / flange materials can be different

- corner tap ⁽⁶⁾ (or 0/0)
with annular slots

➤ The measurement is executed at the upstream and downstream plate edge

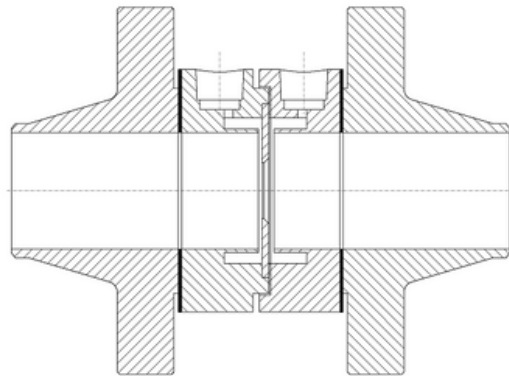

- Assembly used for better accuracy : averaged upstream and downstream pressure taps
- Mounting between simple flanges (welding neck, slip-on...)
- Flange / annular slots materials can be different

- illustrations with a RF orifice plate - the same types of pressure taps also exist in RTJ
- For a nozzle assembly, always consider corner pressure taps

REQUIREMENTS FOR CIRCULARITY AND ROUGHNESS VALUES according to ISO 5167

- Upstream pipe roughness: Ra roughness values specified in the standard (variable according to β and ReD) to be respected over a length of 10D upstream of the primary element
- Upstream pipe circularity: Value of the internal diameter D must be $\leq D \pm 0,3\% D$ to be respected over a length of 2D upstream of the primary element
For a length between 2D and 10D, no additional uncertainty of the discharge coefficient if the maximum circularity tolerance remains less than $\pm 0,3\% D$
- Downstream pipe circularity: Value of the internal diameter D must be $\leq D \pm 3\% D$ to be respected over a length of 2D downstream of the primary element (measured from the upstream face of the primary element)

(6) for a flange tap (1"/1") or corner tap (0/0) monobloc version, see the corresponding datasheets.

STRAIGHT LENGTHS

Required straight lengths between **conditioning orifice plate** and fittings - 2D upstream / 2D downstream

- Required straight lengths between **single hole orifice plate** and fittings - without flow conditioner
- Values expressed as multiple of pipe internal diameter, D

UPSTREAM SIDE OF ORIFICE PLATE

Downstream side of orifice plate

d/D	Single 90° bend or two 90° bends in any plane S>30S	Two 90° bends in the same plane 30D≥S≥10D	Two 90° bends in the same plane 10D≥S	Two 90° bends in perpendicular planes 30D≥S≥5D	Two 90° bends in perpendicular planes 5D>S	Single 90° tee with or without extension	Single 45° bend or two 45° bends in the same plane S≥22D	Concentric reducer 2D to D over a length of 1,5D to 3D	Concentric expander 0,5D to D over a length of D to 2D	Full bore ball valve or gate valve fully open	Abrupt symmetric reduction	Thermometer pocket or well of diameter ≤ 0,03D	Columns (columns 2 to 11) and densitometer pocket													
	1	2	3	4	5	6	7	8	9	10	11	12	13													
≤0,2	6	3	10	10	19	18	34	17	3	7	5	6	12	6	30	15	5	3	4	2						
0,40	16	3	10	10	44	18	50	25	9	3	30	9	5	12	8	12	6	30	15	5	3	6	3			
0,50	22	9	18	10	22	10	44	18	75	34	19	9	30	18	8	5	20	9	12	6	30	15	5	3	6	3
0,60	42	13	30	18	42	18	44	18	65	25	29	18	30	18	9	5	26	11	14	7	30	15	5	3	7	3,5
0,67	44	20	44	18	44	20	44	20	60	18	36	18	44	18	12	6	28	14	18	9	30	15	5	3	7	3,5
0,75	44	20	44	18	44	22	44	20	75	18	44	18	44	18	13	8	36	18	24	12	30	15	5	3	8	4

Notes :

The minimum straight lengths required are the lengths between various fittings located upstream or downstream of the orifice plate and the orifice plate itself.

Straight lengths shall be measured from the downstream end of the curved / conical portion of the nearest bend or tee or reducer or expander to the upstream face of the orifice plate.

In the columns, left values give lengths corresponding to zero additional uncertainty (see ISO 5167-1 standard)

Right values give lengths corresponding to 0,5% additional uncertainty (see ISO 5167-1 standard). Empty cells when no available data.

S is the distance between two fittings..

l

ACCESSORIES

For flow measurement, we offer a full range of accessories for assembly with meter runs.

■ Transmitter



Differential pressure transmitter, multivariable transmitter

■ Manifold



2-way / 3-way / 5-way manifold with or without direct mounting

■ Condensation pot



■ Valve



■ Siphon



■ Fittings



■ Flow straightener or conditioner



FURTHER INFORMATION

All information on the mounting of meter runs (and their accessories) such as :

- pressure taps orientation
- mounting of the differential pressure transmitter
- flange tightening

can be found on the IOM notice "User guide - Installation, operation and maintenance manual" ref DTF-SMQ-P3-IOM-021 provided on request upon the delivery of components.

ITEM CODES

- Meter run : DMR-DN-PN-Face type face-Material

DMR	ND ⁽⁷⁾	NP	Face type	Material
Nominal diameter - ASME	1/2" to 12"	150# to 2500#	RF RTJ SEM ⁽⁸⁾ SEF ⁽⁸⁾ DEM ⁽⁸⁾ DEF ⁽⁸⁾	304L 316L Others
OR				
Nominal diameter - ISO	DN15 to 300	PN2,5 to 400		

- Examples meter run codes:

- DMR-3-600-RF-316
- DMR-DN25-PN64-RF-304

(7) For diameters outside this range, there are solutions. See explanation on page 3.

(8) Specify large or small male/female face if flanges according to ASME B16-5 standard.



Chemin Les Augas – RD817
64170 LACQ
FRANCE



delta64@deltafluid.fr



+33 (0)5 59 30 85 20



www.deltafluid.fr



DELTAFLUID