

CONE METER

KEY DATA

- Cone meter design and manufacturing according ISO 5167-1 & ISO 5167-5 standards
- Recommended for gas, liquid or steam
- Inside pipe diameter : from 50 mm to 500 mm - beyond, contact us
- Reynolds number from $8 \cdot 10^4$ to $1,2 \cdot 10^7$
- Accuracy : from 5% of the max flowrate (without calibration) up to $\pm 0,5\%$ with calibration (recommanded)
- Repeatability of measurement : 0,1%

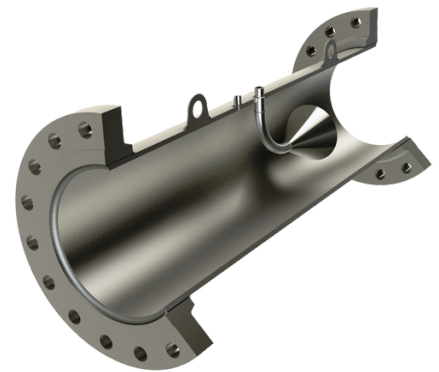

cone meter with flanges

➤ BENEFITS ◀

- Suitable for low flowrates measurement
- Short straight length requirements, weight- and space-saving solution
- Dimensional precision of the cone according to ISO standard
- Cost-effective measurement system : low installation cost and maintenance-free
- Very long life-time product, no drift over time



The cone meter is optimal for flow measurement when a space-saving solution is needed: upstream and downstream required straight lengths are reduced. Which also makes it a device often suitable for renovation. It is designed and manufactured according to the ISO 5167-5 standard. The noted measurement accuracy is 5% of the maximum flow rate. Calibration of the device is recommended in order to increase the measurement precision and know the uncertainty of the discharge coefficient.

STANDARDS

- ISO 5167-1 & ISO 5167-5
- Pressure Equipment Directive PED 2014/68/UE

TECHNICAL CHARACTERISTICS

- Fluid temperature⁽¹⁾: cryogenic to +800°C
- Fluid type : gas, steam, liquid
- Cone materials⁽²⁾ : carbon steel, stainless steel, monel, hastelloy, inconel, duplex, super duplex, titanium, tantalum...
- Body materials⁽²⁾: carbon steel, stainless steel, monel, hastelloy, inconel, duplex, super duplex, titanium, tantalum...
- Maximum operating pressure : limited by the flange rating
- Flange mounting or to be welded (BW)
- Characteristics according to the ISO 5167-5 standard :

		ISO 5167-1&5
ReD	Reynolds number in the pipe	$8.10^4 \leq ReD \leq 1,2.10^7$
D	Inside pipe diameter	$50mm \leq D \leq 500 mm$
$\beta^{(3)}$	β ratio	$0,45 \leq \beta \leq 0,75$
Ra	Cone roughness	$Ra < 5.10^{-4} . d_c$
L	Distance between upstream and downstream pressure tap	$50 mm \leq L \leq 2.D$

(1) No temperature restriction with remote-mounted transmitter, otherwise +125°C max

(2) For an aggressive fluid, applying a specific coating on the cone and its section of pipe can increase the product lifetime

(3) $\beta = \sqrt{1 - \frac{d_c^2}{D^2}}$ d_c , L and D values shown on next page

DRAWINGS

■ Cone meter with flanges

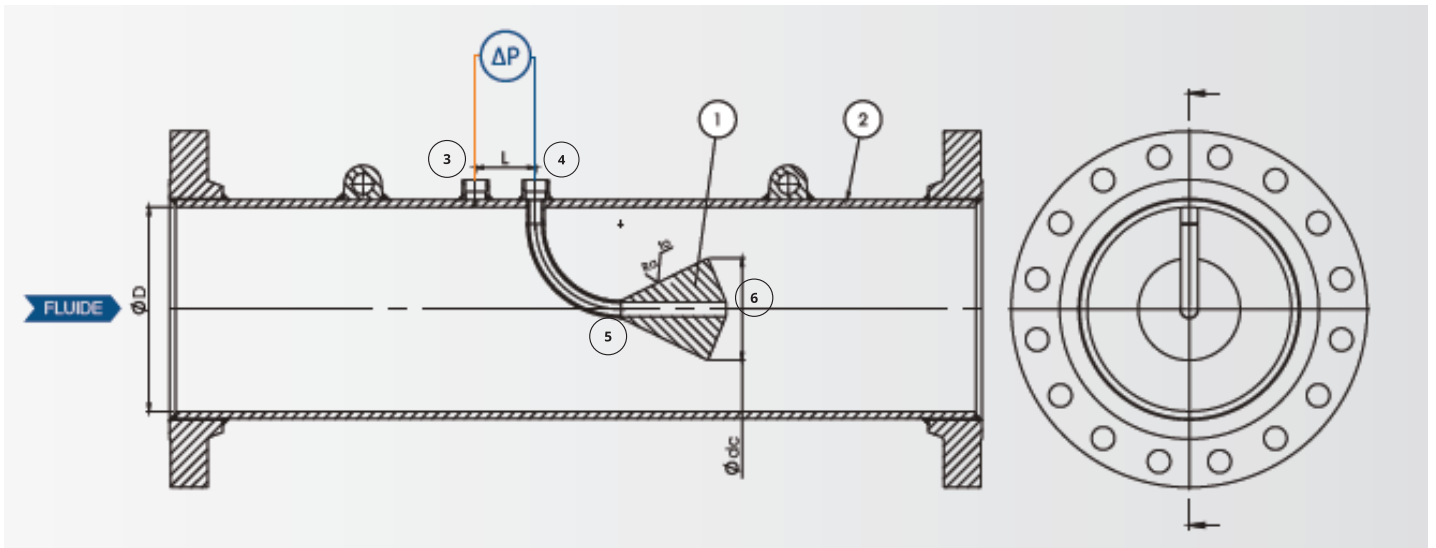

- ① Cone ② Pipe ③ Upstream pressure tap ④ Downstream pressure tap ⑤ Cone nose
⑥ Back side of the cone

DESCRIPTION

- The cone is a primary element composed of a conical restriction and is assembled so that its axis is concentric with the axis of the section of the pipe in which it is fixed. The cone meter described here consists of a section of pipe with a diameter D (②) in which the cone (①) is fixed and of the upstream (③) and downstream (④) pressure tap connections necessary for the measurement.
- The downstream pressure tap (static pressure tap) located in the rear face of the cone (⑥) is connected to the pipe via the cone support bar.

STRAIGHT LENGTHS

■ Sectional view :

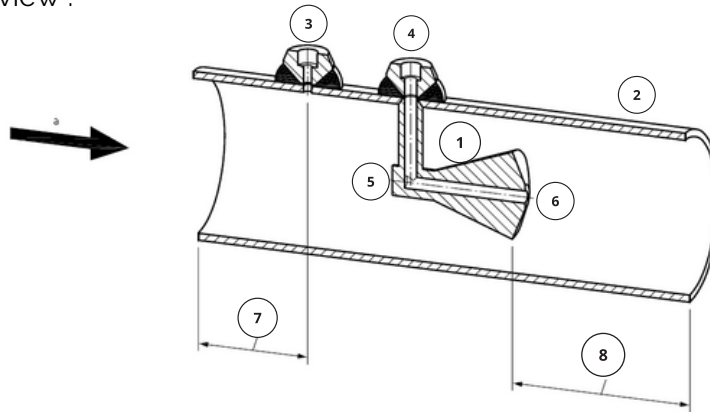

- (1) Cone meter (2) Pipe (3) Upstream pressure tap (4) Downstream pressure tap (5) Cone nose
 (6) Back face of the cone (7) Upstream straight length (8) Downstream straight lengths

	Upstream				Downstream
	Single 90° bend	Two 90° bends in perpendicular planes	Concentric expander from 0,75D to 1D	Gate valve partially closed	Fittings cited in previous columns
$0,45 \leq \beta \leq 0,6$	3D	3D	3D	10D	2D
$0,6 \leq \beta \leq 0,75$	6D	6D	3D	10D	2D

Upstream straight lengths are measured from the plane passing through the axis of the upstream pressure tap of the cone as illustrated in the figure above in (7).

Downstream straight lengths are measured from the plane of the beta edge of the cone meter as illustrated in the figure above in (8).

A thermowell can be mounted downstream of the cone at a distance between 5D and 15D from the beta edge of the cone as illustrated in the figure above in (8).

ACCESSORIES

For flow measurement, we offer a full range of accessories for assembly with cone meters.

■ Transmitter



Differential pressure transmitter, multivariable transmitter

■ Flanges

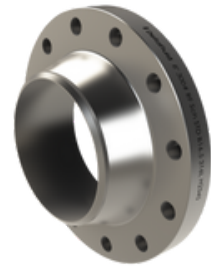

Flanges with flat gasket face, raised face, large male/female face, tongue/groove face, RTJ-F face

■ Manifold



2-way / 3-way / 5-way manifold with or without direct mounting

■ Condensation pot



■ Flow straightener or conditioner



■ Valve



■ Siphon



■ Fittings



FURTHER INFORMATION

- All information on the mounting of cone meters (and their accessories) such as:
 - pressure taps orientation
 - mounting of the differential pressure transmitter
 - flange tighteningcan be found on the IOM notice "User guide - Installation, operation and maintenance manual" supplied on request upon delivery of parts

ITEM CODES

- Cone meter : DVCONE-DN-PN-Material

DVCONE	ND	NP	Material ⁽³⁾
Nominal diameter - ASME OU	2" to 20"	150# to 2500#	Carbon steel 304L 316L Others
Nominal diameter - ISO	ND50 to 500	NP2,5 to 400	

- Examples cone meter :

- DVCONE-16-300-304 (ASME)
- DVCONE-300-40-AC (ISO)

(3) The cone itself and the section of the pipe in which it is fixed can be made of 2 different materials. For the corresponding code, note the material of the cone followed by the material of the tube as follows:
example : DVCONE-12-600-304+AC



Chemin Les Augas – RD817
64170 LACQ
FRANCE



delta64@deltafluid.fr



+33 (0)5 59 30 85 20



www.deltafluid.fr



DELTAFLUID